



Wavelet Transforms in Financial Time Series Analysis: A Review on Stock Price Prediction

Kuon Keong Lock^{1,*,}    and Razali Yaakob^{1,*,}   

¹Faculty of Computer Science and Information Technology, Universiti Putra Malaysia, Malaysia

Article History

Received: 10 July, 2025

Revised: 15 October, 2025

Accepted: 05 November, 2025

Published: 09 January, 2026

Abstract:

Introduction: Stock price prediction is notoriously tricky due to data complexities such as non-stationarity and noise.

Methods: This literature survey was conducted in order to systematically evaluate how wavelet transforms enhance forecasting by improving data preprocessing for machine learning models.

Results: The review of hybrid wavelet-ML architectures (e.g., LSTMs, Transformers) finds that they consistently outperform standalone models by leveraging wavelets' powerful denoising and multi-scale feature-extraction capabilities. Despite their effectiveness, persistent challenges include parameter optimization, model interpretability, and overfitting.

Conclusion: Future research priorities should include adaptive wavelet techniques and the development of more robust, transparent hybrid systems for practical financial applications.

Keywords: Wavelet transform, time series data, machine learning, stock price prediction, denoise data, stock price trend.

1. INTRODUCTION

1.1. The Challenge of Financial Forecasting

Predicting financial time series, such as stock prices, foreign exchange rates, and commodity price movements, has historically been a rather challenging task. The high volatility and market uncertainty make it difficult for investors to achieve profits and predict stock performance [1]. They are highly complex and contain non-stationarity (statistical properties of the series change over time); a high noise-to-signal ratio that obliterates any underlying structure; a considerable degree of non-linearity, rendering linear models useless; and volatility clustering: significant returns are more likely to be followed by significant returns, and calm periods become quieter. So, they are susceptible to sudden changes or structural breaks against unforeseen economic, political, and social events [2]. These properties make financial forecasting difficult [3].

Some of the big questions that make financial forecasting different from other areas are. First, the competitive environment

induced by time pressure and market efficiency concerns typically results in a low signal-to-noise ratio, particularly in the context of asset return predictability [4], so that imperfect forecasters are often the norm rather than a rarity [5]. For no predictability at all, the error implies that parameter estimates scale to order one [5]. Second, the mere strategy of using predictability can cause the predictable pattern to break down when prices move in response, leading to model-free instability [5]. Therefore, this type of volatility must be included in the QS analysis: even if we are predicting for a set of variables at one future period, there is still predictability, and no forecasting model can be best-performing at all times [5].

In financial markets, the non-linear and singsong nature of despisers such as dissection-of-scale is even more pronounced, making precise prediction less useful for some existing machine learning techniques due to these complexities [6]. Indeed, there are multiple dimensions in which financial forecasting is variable-based and values that need to be future-looking whilst they do not exist at the moment [7]. Traditional statistical models, such as

*Address correspondence to this author at Faculty of Computer Science and Information Technology, Universiti Putra Malaysia, Malaysia; E-mail: GS67790@student.upm.edu.my & razaliy@upm.edu.my



© 2026 Copyright by the Authors.

Licensed as an open access article using a [CC BY 4.0 license](https://creativecommons.org/licenses/by/4.0/).

ARIMA (Autoregressive Integrated Moving Average) and GARCH (Generalized Autoregressive Conditional Heteroskedasticity), have been dominant for quite a long time in financial time-series analysis. While these methods constitute the main framework for the comprehension and prediction of financial data, it was discovered that they suffer from severe limitations in modeling a rich family of complex patterns and relationships that are nonlinear across the general behavior of financial markets. Traditional accounting, operating and forecasting are to some extent fairly logical, but they frequently are not able to represent changeable dynamics of these environments and non-linear financial structures with dynamic costs and market states [7]. For instance, [2] argues that ARIMA is too simple to be useful, as it fails to capture the complex patterns and non-linear causal structures required for effectively predicting trends in a dynamic stock market environment [2].

Say the problem of financial forecasting is directly related to the Efficient Market Hypothesis (EMH), which, when formulated strongly, means that all public information is reflected in asset prices [6]. Therefore, it is impossible to obtain excess risk-adjusted returns by using forecasts. However, note that return predictability is not ruled out by no-arbitrage if it represents inter-period variation in the risk premia or in the pricing kernel [5]. Despite being a logically derived consequence of the EMH, the question of forecasting in financial markets has itself constituted a long-standing and productive research path for well over 50 years. Meanwhile, the continuing concern about marginal gains in predictability reflects the intense belief deeply held by both academics and practitioners in this research field that predictive signals should be available. If they find such microstructures, it may be patterns of irrationality, or passing inefficiencies that fail not only of the weak form (which allows for markets not perfectly efficient but relatively close to it), or cases where even a slight improvement in forecast accuracy can give you large economic/strategic rents. Indeed, even small amounts of predictability are systematically associated with substantial economic gains for the concerned investors (though transaction costs and market impact are virtually never accounted for in this type of analysis [5]). However, it remains, and new state-of-the-art research continues to emerge.

To provide an example, the joint application of wavelet analysis and machine learning methods remains a testament to this tenacity in deciphering the complex code of financial markets [2]. However, data mining per se is an issue as well; overfitting of the relations among variables leads to serendipitous findings of spurious, hard-to-fix, predictable patterns in many tested models [5]. It was also noted that while some median AI models worked, it is not yet reasonable to claim that, with current artificial intelligence technology, we have an AI model that beats the stock market [7].

1.2. Wavelet Analysis: A Primer for Financial Data

While searching for better techniques to examine complex financial time series across various areas of finance and economics, wavelet analysis has proven to be a formidable signal analysis methodology. Most conventional time series analysis techniques assume stationarity, which is rarely encountered in

economic and financial time series, which are typically non-stationary, nonlinear, subject to structural changes, and exhibit volatility clusters [8]. Wavelet analysis has the benefit over conventional techniques of not assuming time-series stationarity and of extracting information that is not discernible with standard techniques [8, 9]. While all conventional techniques analyze data in either the time or frequency domains, wavelet analysis offers the distinct advantage of simultaneously analyzing time series in both domains [10]. Such a combined time-frequency representation (TFR) is important because the spectral content of non-stationary series, such as financial series, changes over time, making standard Fourier theory unsuitable [11]. Wavelet transforms (WT) were found to be superior to Fourier transforms for analyzing non-stationary data, making them a potential tool for time-series decomposition [12]. Such capability is realized chiefly through multi-resolution analysis (MRA), which is fundamental to wavelets' ability to decompose a signal into several frequency bands at different scales, that is, resolutions. MRA is responsible for decomposing time-series data into low-frequency (approximation) and higher-frequency (detail) sub-series in the wavelet realm [12], making it possible to hierarchically investigate data from the large picture to the finer details and, by doing so, isolating tendencies that may be hidden within the total signal. Such a capability is particularly appropriate for financial data, whose salient events and latent structures tend to manifest at different time horizons, ranging from short-term fluctuations to long-term trends [13]. Wavelet transforms can decompose complex financial signals into simpler components, thereby enabling the detection of hidden structures, trends, and periodicities that are often obscured by natural noise in financial data [13]. Indeed, wavelet analysis can conduct a multi-scale, detailed examination of signals, effectively filtering out noise while retaining the features of the original signals [14]. The main advantage of wavelet decomposition is that it is possible to extract the trend from the data and to filter out spurious short-term fluctuation [12]. Wavelet analysis was initially employed to address the problem of detecting abrupt signal changes across diverse branches of the natural sciences, for example, in the theory of seismic waves [15], and is therefore particularly suitable for financial time series that often undergo abrupt changes and structural breaks [16]. An idea of wavelets, transplanted from signal processing, offers interesting application prospects for periodicity-based time series, as well as for short- and long-term cycles [17].

1.3. Machine Learning in Financial Forecasting

Over the last two decades, there has been a clear shift in the paradigm of financial forecasting, driven mainly by the development of machine learning (ML) and, more recently, deep learning (DL) methods [2]. The fusion of ML and AI has ushered in a new revolution in finance, enabling more accurate predictive analytics of asset prices and market trends beyond the reach of statistical models [18]. ML can be used for dimensionality reduction or as a dimensionality filler, especially when we need to use multiple combinations of N dimensions and forecast into the future [7]. These data-driven approaches have been shown to learn excellent nonlinear relationships purely from large historical datasets (a challenge for traditional statistical models).

Different ML models, for instance, Artificial Neural Networks (ANNs), Support Vector Machines (SVMs), decision trees [7], random forests [18], Recurrent Neural Networks (RNNs), Long Short-Term Memory (LSTM) networks and various deep learning architecture like CNNs and hybrid models [19] have shown much promise for application to financial forecasting problems [2]. RNNs, for instance, have excelled at handling sequential data, although they can be prone to gradient explosion or vanishing when dealing with large datasets, which can cause them to forget the preceding data and hence produce incorrect estimates [1]. LSTMs are the upgraded version of RNNs, with gates that address these issues [12]. Similarly, [17] describes the rediscovery and widespread adoption of NN-based AI in the 2010s, driven by the availability of data and computational capabilities, and demonstrates their suitability for financial time series. These models can accommodate complex dependencies and adapt to shifting market forces. However, their use can be severely hindered by the coarse nature of financial data. High noise levels, non-stationarity, and the presence of outliers can lead to suboptimal model learning, poor generalizability to test data, and, ultimately, questionable estimates [2]. Various macroeconomic and microeconomic variables influence financial markets, and the actual impact of these variables on the financial system is rarely known; thus, financial data is inherently messy and unpredictable [14]. As noted by [2], prediction results in extensive data analysis, particularly in finance, could broadly vary based on data preprocessing methods employed [2]. Similar to [11, 12] maintains that preprocessing is a crucial step before data modeling, as it can improve performance and increase prediction precision. It highlights the pivotal role of robust data preparation methodologies, such as wavelet analysis, as cited in the current survey [8], in realizing the full potential of ML models. Nevertheless, problems related to data quality, model interpretability, and ethical issues persist [9].

2. WAVELET-BASED PREPROCESSING TECHNIQUES

2.1. Core Concepts of Wavelet Transforms

Wavelet transform is a mathematical tool to decompose the time series into different events at different frequency ranges and study the data in several scales or resolutions [20]. Their tool for this purpose is the MRA, which leads to the theory of wavelets [10].

In MRA, a signal is represented as a sum of approximation coefficients corresponding to low-frequency coarse features (*e.g.*, long-term trends) and detail coefficients representing high-frequency fine details (*e.g.*, short-term noise or variability). Observe MRA reconstructing multi-scales both in the absence of measurement noise. An important advantage of wavelets, as with most local transformations, is that they are efficient in the time-frequency plane, unlike the Fourier transform. Although the Fourier transform tells us which frequencies are in a signal, it discards information about when they occur. It is desirable to draw the readers' attention to the fact that, because wavelets are local in both time and frequency, they can directly indicate when frequencies occur and which frequencies are present [10].

This is particularly useful for the investigation of non-stationary financial time series, where statistical properties biased toward some frequency can evolve considerably over time. If we want to arrive at a mathematical wavelet, it is the expansion of a signal in terms of various (scaled and shifted) versions of the exact basic wavelets (mother wavelet). The scaling is like letting a lot of different frequency bands through on the analysis, and the translation is so we can localize where in time we allow that sort of filter. Although I cannot present a complete mathematical treatment here, the simple idea of the mother wavelets, translation, and scaling should be enough to understand how they are used.

The multiresolution decomposition of a signal $X(n)$ using a three-level DWT is shown in Fig. (1). At Level 1, the input signal is effectively passed through both a low-pass and a high-pass filter simultaneously. The low-pass filter retains the low-frequency contents (approximations cA_1), and the high-pass filter extracts the high-frequency components (details cD_1). The two resulting outputs are also downsampled by a factor of 2. This decomposition process is recursive; the approximation cA_1 coefficients are then filtered again through a similar filter bank at Level 2 to produce a new level of approximation (cA_2) and detail (cD_2) coefficients. This process is repeated up to Level 3, where the final approximation (cA_3) and detail (cD_3) coefficients are obtained, representing that $X(n)$ consists of different frequency components.

2.2. Common Wavelet Families

Selection of an appropriate mother wavelet is based upon a few prominent qualities, which affect its independent operation. Due to orthogonality, the energy of a signal is preserved under the transform and, hence, is also fast to reconstruct. Vanishing moment number is also valid; the wavelets that contain N vanishing moments are not affected by trends of polynomials of order $N-1$ and are therefore well adapted to signal compaction, like local features extraction. For example, the Daubechies 'dbN' series contains N vanishing moments. Finally, additional qualities such as support (how local in time the wavelet analysis is) and symmetry (which may be used to avoid phase distortion during analysis) are also of interest. For example, Haar wavelets are non-continuous and therefore optimal for detecting sharp jumps. In contrast, smoother variants such as Daubechies or Symlet wavelets are preferred for trend analysis of less erratic data.

The choice of the mother wavelet is a critical aspect of wavelet analysis, as its shape and inherent properties determine how a signal is broken down and which features are highlighted. It is said that different wavelet families analyze different characteristics of the financial data better [21, 22] and finding an "optimal" wavelet for any given dataset is an important issue to be performed to get accurate results in modeling and forecasting [23, 24]. Wavelet transforms are conventionally used to decompose financial time series into components that can be analyzed or forecasted separately [25-27], often improving performance against models with raw data. They are a powerful tool for analyzing nonlinear dynamics, especially in the high-frequency domains of financial data such as cryptocurrencies [28], and for capturing cyclical characteristics at different time scales [29]. Wavelet denoising is another important application that aims to separate signals from noise before further processing or prediction [30, 31].

- Haar:** The Haar wavelet is the simplest and oldest type. It works by representing signals as step-like functions, making it effective for detecting abrupt changes or discontinuities in signals [13] and for compactly representing signals and images [32]. It is computationally efficient, but its abrupt nature may not be ideal for smooth financial data and it may produce noisier series than smoother wavelets when studying stationarity [33, 34]. It is also known as the B-spline wavelet of order 1 (BS1) [35]. It has been used in the Wavelet Deep Average (WDA) model for cryptocurrency prediction [36] and in conjunction with db8 for DWT denoising [16]. [37] Conducted a comparative study including Haar wavelets for agricultural price forecasting. The SWIFT model also utilizes the Haar wavelet due to its computational efficiency and stable transformations [38]. Haar wavelets are also employed with ARIMA models for forecasting financial time series [36, 37], for modeling the banking sector [37], and for decomposing yield spreads in wavelet neural network models [22]. They have been used as a wavelet-based OLS estimator to investigate long-term memory in stock prices [39] and are mentioned in the context of jump detection in high-frequency data analysis using MODWT [40]. Comparative analyses show that Haar can effectively capture the characteristics of financial data [41]. Furthermore, Haar wavelets are used to approximate the distribution of credit portfolio losses [42]. In some numerical studies on financial data, Haar has been found

to perform well in solving autocorrelation problems and denoising data [43]. It is also used for noise reduction in trading systems [44] and is a fundamental DWT family for analyzing high-frequency data [45].

- Daubechies (dbN):** This family provides a good balance of properties for general signal analysis, including financial time series. These wavelets are orthogonal, compactly supported, and their smoothness increases with the order 'N', making them effective for capturing trends and specific events within data [40]. The 'N' in dbN refers to the number of vanishing moments [13, 15]. Specifically consider Daubechies wavelets as input features for forecasting models. They are commonly used for decomposing financial data, [37, 41, 46] and for analyzing financial time series more generally [40]. Specific Daubechies wavelets (such as d4, db5, and La8) have been used in ARIMA-Wavelet models for credit loss forecasting [47] and in wavelet neural networks for yield spread forecasting, with Db4 showing high performance [22]. Daubechies wavelet analysis has been found to provide an accurate determination of long-term memory effects in stock prices [42]. Various orders have been tested for optimality in financial cascade models [23] and for real-time denoising in stock index prediction [39]. D4 is also mentioned for jump detection in high-frequency data [43]. They are also a common choice for analyzing high-frequency financial data [46].

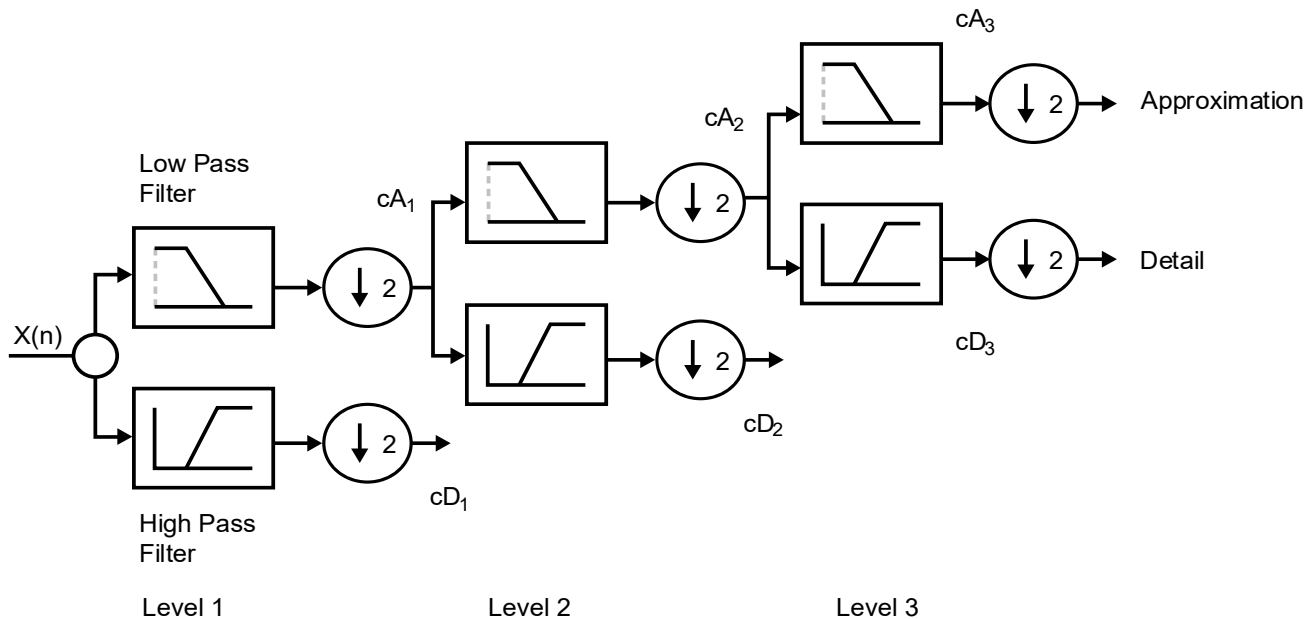

Fig. (1). Diagram of multiresolution analysis of signals [20].

- **Symlets (symN):** Symlets are similar to Daubechies wavelets but are designed to be more symmetric, which can be better for feature analysis when phase distortion is a concern [13]. They have been considered for data decomposition [48], financial time-series stationarity [29, 30, 41], and real-time denoising in stock index prediction [39]. Symlet 7 was identified as potentially optimal for analyzing stock market volatility [23], and Symlet 16 has been used to detect business cycles in GDP data [49]. They are also listed as a DWT family for high-frequency data analysis [47]. Symlets3 specifically has been used to decompose stock market returns for cointegration analysis [32, 50].
 - **Coiflets (coifN):** Coiflets are nearly symmetric and orthogonal, with vanishing moments for both the wavelet and scaling function, proper for data compression and smooth feature representation [28, 51, 52]. The WT-ATT-LSTM model employs Coif3 for denoising [6]. Coiflet wavelet decomposition has been shown to improve ARIMA forecasting for electricity demand [48]. They are also used to study stationarity [41], in ARIMA-Wavelet models for LGD [49], tested for optimality [23], numerically investigated for financial time series [45], used for decomposing yield spreads [22], and for real-time denoising in stock index prediction [39]. They are also a common choice for analyzing high-frequency financial data [46].
 - **Morlet:** This wavelet is well-suited for analyzing wavelike patterns and identifying specific frequency content that changes over time. It is commonly used in CWT for studying time-varying correlations [53, 54], analyzing cryptocurrency price dynamics [38], data mining of financial time series for cyclical components [55], and in wavelet coherence analysis for studying financial market contagion [56]. It can also transform stock price data into 2D scalogram images for anomaly detection [57] and form kernels for SVMs [58].
 - **Meyer:** The Meyer wavelet is infinitely smooth and orthogonal. Its infinite support can sometimes be a limitation. A discrete approximation (dmey) has been used to study financial time series stationarity [34, 41], numerically investigated for financial data analysis [59, 60], used to decompose yield spreads [22], and listed as a DWT family [46].
 - **Biorthogonal (biorNr.Nd) & Reverse Biorthogonal (rbio):** Biorthogonal wavelets offer flexibility with symmetric, linear-phase properties, excellent for perfect signal reconstruction [59]. They are used in various forecasting studies [48], numerically studied for financial data [45], and for real-time denoising in stock index prediction [39]. Specific types, such as Cdf9/7 [61, 62] and Bior (4.4) [58], are used in SVM kernels. Battle-Lemarié wavelets (spline-based, can be biorthogonal) were found optimal for log-price stock data [23] and are listed as a DWT family [46].
 - **B-Spline (BSd) Wavelets:** These provide local DWTs; Haar is BS1 [42]. Higher-order B-splines are smoother, decomposing time series into less erratic components, which is beneficial for ANNs [42]. Battle-Lemarié wavelets are also spline-based [23, 46].
 - **CDF Wavelet:** Mentioned as a DWT family suitable for high-frequency data analysis [46]. (Often Cohen-Daubechies-Feauveau, a type of biorthogonal wavelet).
 - **Shannon Wavelet:** Listed as a DWT family that can be used for high-frequency data analysis [46].
 - **Gaussian Wavelet Kernel:** Refers to using a Gaussian function derivative to create a kernel for SVMs in financial forecasting [58].
 - **General Wavelet Applications in Finance:** Wavelets are widely used to decompose non-stationary financial signals into features capturing multi-scale dynamics [31, 46, 50, 57]. Denoising is a key application, especially for high-frequency data [39, 43]. Wavelet correlation and coherence are used to study market comovement and contagion [54, 56, 63]. Hybrid models combining wavelets with ARIMA or ANNs often improve forecast accuracy [22, 36, 37].
- To aid researchers and practitioners in selecting appropriate wavelet families, Table 1 summarizes standard wavelets, their key characteristics, and their suitability for specific financial data properties, along with example studies. This consolidated view is valuable because the choice of mother wavelet is crucial yet often non-obvious. The table aims to link the mathematical properties of wavelets to the practical characteristics of financial data (e.g., Haar for sharp jumps, smoother wavelets like Daubechies or Symlets for trends). It illustrates these links with examples from the surveyed literature. This can foster more informed methodological decisions by providing practical guidance and reducing the effort required to assess the applicability of each wavelet family individually.

2.3. Wavelet Applications in Preprocessing Financial Time Series

Wavelet analysis offers several powerful methods for preprocessing financial time series data before feeding it into machine learning models. These preprocessing steps aim to improve data quality, extract relevant information, and enhance the overall predictive performance of the models.

2.3.1. Denoising Financial Time Series

Financial time series are inherently noisy, with underlying signals often blurred by random noise, changes in market sentiment, and high-frequency trading. Wavelet transforms are ideal for separating the underlying signal from noise [26, 27, 67, 68]. The procedure usually entails decomposing the signal at various frequency levels, thresholding the detail coefficients (which mainly comprise noise at higher frequencies) to set them to zero, and reconstructing the signal from the modified coefficients [13, 69].

Several thresholding techniques are available. Two of the most popular are hard thresholding, in which the coefficients of details below the threshold in absolute value are set to zero, and soft thresholding, which also sets coefficients of little value to zero and, in addition, shrinks non-zero coefficients toward zero. More adaptive techniques include the universal threshold (VisuShrink) and Stein's Unbiased Risk Estimate (SUREshrink) [55]. The paper by [46], which employed SWT for decomposition-based denoising, includes a denoising/feature augmentation step, and

[45] uses wavelets explicitly to denoise for predicting Bitcoin prices.

These effects on the time series can be dramatic, and wavelet denoising has been shown to yield smoother results with clearer underlying trends, making the denoised time series ideal input data for ML models. The former naturally leads to better prediction accuracy [55]. For instance, [16] showed that denoised stock data had stable trend features and smoothness, which significantly helped their ELM-based prediction model. The consistent success, as seen in numerous studies including wavelet denoising as a first stage, suggests that correcting the huge signal-to-noise ratio of financial data is an essential step for successful ML-based forecasting. To the best of our knowledge, the popularity of wavelet denoising and its promising results indicate that it is not merely a supplementary preprocessing approach, but also strongly recommended and/or even inevitable to improve learning performance in noisy financial domains. It underscores the aphorism that the quality of data required to feed an ML model is paramount, and wavelet denoising becomes a crucial approach to ensure higher input quality, enabling models to learn meaningful, actual underlying patterns rather than occasional ripples [55].

2.3.2. Feature Extraction and Engineering Using Wavelets

Aside from denoising, wavelet transforms are a powerful tool for feature engineering in financial machine learning. One of the closest applications considered in the early work of [13] relies on wavelet coefficients as input features. [51] Provide a recent example of this principle. This simple yet successful strategy, along the lines discussed in Section 2, involves using Daubechies

wavelet coefficients as predictors in their forecasting procedures. However, the above approach is simple, and in recent years, a more sophisticated multiwork item has been used, recognizing that the complete set of coefficients may be high-dimensional and noisy.

This led to calculating a denser collection of statistics on the wavelet sub-bands than on mean, variance, energy, or entropy. It is also notable that complexity-based quantities, like wavelet entropy, have been tested and implemented [6]. [71], among others, demonstrated significant performance gains when using wavelet entropy in deep learning models to forecast stock indices and forex volatility. However, this strategy of having a large pool of features also introduces a new problem: feature selection. The DWT-CSO approach [6] uses a bio-inspired CSO (Chicken Swarm Optimization) algorithm to select the optimal subset of wavelet features, thereby avoiding overfitting.

As observed, it is this transformation to a space in which the one-dimensional time series is rescaled with respect to different scales and locations of (known) features that gives wavelet-based methods their predictive advantage. It allows models to quantify and potentially even harvest an entire class of phenomena that are virtually invisible in raw price data: complex operational regimes of volatility that come and go, faint cyclical behaviors that only reveal themselves over particular timescales, changes in market complexity, and on and on [72, 73].

This approach provides machine learning models with a richer, multi-horizon portrait of market dynamics, allowing them to see finer-grained, scale-dependent patterns governing financial returns across many scenarios.

Table 1. Summary of wavelet families and their characteristics for financial data.

Wavelet Family	Key Characteristics	Suitability for Financial Data Properties	Example Studies
Haar	Discontinuous, Orthogonal, Compact Support	Detecting abrupt changes, price jumps, structural breaks; Computationally very efficient.	WDA for crypto [43], SWIFT model [41], Part of DWT denoising with db8 [16], Agricultural prices [44]
Daubechies (dbN)	Orthogonal, Asymmetric, Compact Support, N vanishing moments	Good general-purpose; Smoothness increases with N; Capturing trends and localized events.	Feature input [47], Agricultural prices [44]
Symlets (symN)	Near Symmetric, Orthogonal, Compact Support	Similar to Daubechies but with less phase distortion; Good for feature analysis.	General time-series analysis [13]
Coiflets (coifN)	Near Symmetric, Orthogonal, Vanishing moments for ϕ & ψ	Good for compression and signal reconstruction; Smooth feature representation.	WT-ATT-LSTM for NIFTY 50 denoising (Coif3) [55].
Morlet	Non-orthogonal, Complex-valued, Gaussian-shaped	Analyzing oscillatory patterns, frequency content, and time-varying correlations (e.g., in wavelet coherence).	Wavelet coherence analysis [64]
Biorhogonal	Symmetric, Linear Phase (allows perfect reconstruction)	Signal reconstruction, applications where phase is important.	Bior (4.4) wavelet kernel SVM (older study) [65, 66]

3. HYBRID FORECASTING MODELS

Wavelet transforms are better predictors, in terms of relative RMS prediction errors, when used both as a preprocessing step and as the primary processing step within a hybrid model [74]. The literature indeed claims that there is a strong consensus that, for any ML algorithm, using its wavelet decomposition as a feature space yields better generalization than applying one of these techniques alone. All the arguments around synergy apply to this combination.

Wavelets are noise-diggers, and there is nothing else they do or multiply with directly to the features (unless more complex representations other than just removing noise where latent patterns can hide are made, *i.e.*, denoising raw time series, coding a richer, multi-scale set of values, *etc.*). This provides a much cleaner, more organized view of market dynamics for the ML model to learn from, resulting in much higher efficiency and accuracy [75]. Therefore, this part will investigate the most impactful ML architectures used as engines for these strong hybrid frameworks.

3.1. Wavelet-Neural Network Hybrids

Given that financial markets are complex and highly non-linear, Neural Networks (NNs) have become central to predictive modeling. Their great strength lies in their generalization power: they are universal function approximators that can learn complex dependencies that classic linear methods cannot model. It is particularly compelling in conjunction (synergetically) with wavelet preprocessing [76].

Wavelets handle the complexity of the preprocessed data. They separate a noisy, time-varying signal into primitives and more stable elements. This enables the NN to master valuable regularities in the field and thus achieve more than reported in the literature [77, 78]. This is in line with the trend toward the application of hybrid financial models and aligns with earlier research, such as contrasting different network configurations [79, 80] or NNs coupled with statistical forecasting models, such as ARIMA, to boost forecasting performance [81].

- **Multi-Layer Perceptrons (MLPs):** An example of a feedforward network is the Multi-Layer Perceptron (MLP). Those values as Universal Function Approximators attest to its inherent richness, not only as an autonomous approach but also as a torchbearer of more evolved practices. For instance, WaveletMixer [82] adopts an MLP as a learning model to process bit-expensive time-series data. This encapsulates an important role for MLPs in modern finance: once we are done with the feature space from a temporal perspective, we are left with a non-trivial, dynamic, and non-linear structure that needs to be modeled. This flexibility can therefore be seen in the different types of applications in which it has been applied over time: from fundamental work in forecasting stock and exchange rates [83, 63] to more recent research on cryptocurrency price dynamics [80].
- **Recurrent Neural Networks (RNNs):** To address this and the time series component of financial data, one of the most revolutionary developments was that of Recurrent Neural Networks (RNN). RNNs differ from feedforward neural

networks because they have a feedback structure, allowing the memory of the neuron's internal state to be maintained. In theory, such a design can learn from sequential data effectively. However, this intuition is ruined by a severe and well-known problem: the vanishing gradient and exploding gradient. This makes classical RNNs so hard to learn long-range dependencies, which are crucial in financial markets. While some researchers remained unhappy and proposed enhancements, the net effect is that essentially nobody today uses these base RNNs for "main" forecasting. However, they provide a valuable basis for comparing more sophisticated algorithms (such as LSTMs or wavelet-hybrid methods) [84, 85].

- **Long Short-Term Memory (LSTM) Networks:** LSTM is ultimately the solution to the vanishing gradient problem in vanilla RNNs. Its power stems from a clever gating mechanism which a set of input, forget, and output gates that carefully manage which information is allowed to flow through the network's memory cells. It is this architecture that endows LSTM with the ability to memorize useful information for a period of time, not only short ones, but even very long ones (and, in an ideal world, flush out useless noise in the data), a property that has made LSTM the workhorse model for forecasts of financial time series [86]. Accordingly, the literature is abundant with successful wavelet-LSTM hybrids, particularly due to their success across multiple disciplines, ranging from [87, 88], indices and trend prediction markets to commodity price computation [44]. They perform favorably in many comparative studies [89] and are a reliable, robust device for capturing the non-linear characteristics of markets.
- **Gated Recurrent Units (GRUs):** Inspired by the success of LSTMs, the Gated Recurrent Unit (GRU) emerged as a promising alternative, primarily for greater computational efficiency. It does so via a simplified architecture that merges the LSTM's input and forget gates into a single "update gate," thereby reducing the total parameter count. The surprising fact, as noted by [55, 90], is that GRUs generally perform quite similarly to LSTMs in terms of quality of results while requiring much less training time, an essential characteristic in practice [91]. This optimal mix of power and efficiency has positioned it as a preferred choice for recent wavelet hybrids. Recently, research demonstrated the superiority of SWT with optimized GRUs for Stock Prediction [6] and Bidirectional GRUs for volatility in assets like Bitcoin [80].
- **Convolutional Neural Networks (CNNs):** As opposed to the line-by-line manner in which RNNs solve the prediction problem, Convolutional Neural Networks (CNNs) adopt an entirely distinct strategy for modeling and predicting time series data, namely pattern recognition [92, 93]. Initially developed for image recognition, they work by using convolutional filters that serve as learnable detectors of specific shapes or patterns in the data. The underlying premise is that a time series of asset prices or other financial instruments can be considered as a 1D "image," in which pattern repetition (similar to classical chart patterns) could have some forecasting property. Architectures such as SincNet are specifically designed to solve the task of signal

classification [94]. This new paradigm has even led to the creation of image-like representations of financial data for example, heatmaps of a limit order book enabling the use of standard 2D CNNs for price prediction [95]. They also serve as strong feature extractors within more general hybrid systems, such as the CNN-SVM model introduced in [76].

- **Graph Neural Networks (GNNs):** One important direction to this end is that one should look beyond individual time series and model the whole market as a system with its feedback on itself and this is where Graph Neural Networks (GNNs) step in. Where they excel is in modeling intricate cross-asset dependencies such as supply chain relationships among firms, sentiment propagation within an industry, and competitive effects. For instance, the Multi-Modality Graph Neural Network (MAGNN) introduced by [91], is an excellent demonstration of the power in this. From that graph, along with others constructed from various data sources including historical prices, news sentiment, and industry knowledge graphs, the model can learn how information travels through the market network to predict more effectively but in a more nuanced manner.
- **Probabilistic Neural Networks (PNNs):** While many networks predict a specific future value (regression), predicting up or down is often more useful (classification). To achieve this, the Probabilistic Neural Networks (PNNs) have been a non-orthodox alternative. In the Bayesian framework, PNNs are trained to classify inputs into N discrete classes by producing probability density functions for each class. Pioneer work of [74] proved their capability by providing a strong prediction of the direction of three stock indices. This change of viewpoint is important because the direction you choose to align in is often the overwhelming determinant of performance for most trading systems.
- **Quantile Regression Neural Networks (QRNNs):** QRNNs, a type of feedforward neural network, can estimate nonlinear models at different quantiles. PSOQRNN, a particle swarm-optimized QRNN, has been proposed for forecasting financial time-series volatility [75].
- **Deep Q-Networks (DQN):** DQNs, which combine deep neural networks with Q-learning (a reinforcement learning algorithm), have been applied to financial applications, such as optimizing money management policies [84].
- **Other Architectures:** Dynamic Artificial Neural Networks (DANs) and General Regression Neural Networks (GRNNs) are also mentioned for stock market prediction and volatility forecasting respectively [75, 83]. Radial Basis Function (RBF) networks are another type used in exchange rate forecasting [63].

3.2. Wavelet-Transformer Hybrids

The gated RNN was indeed a significant advancement. However, the more recent use of the Transformer architecture, which originates from Natural Language Processing, represents a true breakthrough for time series forecasting [85]. Their pivotal advancement is the self-attention mechanism. Unlike recurrent neural networks (RNN) which process input sequentially, attention-based models can consider all previous data points at

once. This ability is especially beneficial for modeling long-term, non-linear relationships typically found in financial data. Building on this, several time-series analysis Transformer-based models, such as Informer, Autoformer, and PatchTST, have been developed [51].

Wavelet analysis and Transformers is a unique and emerging area of study, as the attention mechanism allows for modeling complex financial signals at a higher level after wavelets decompose the signal into simpler components. This concept is simple, yet offers a powerful combination of signal decomposition and attention modeling. Researchers have attempted a variety of integration methods. Some models, for example, directly input wavelet-based multi-resolution features into the Transformer, which generates rich multi-resolution features [51]. Others, such as the SWIFT model, apply wavelets for down-sampling to reduce computational cost while preserving important signal attributes [45].

Nonetheless, progress has achieved several hurdles. The intricacy of dual structures increases the tendency toward overfitting, particularly due to noise in the financial environment. Also, their "black box" nature raises concerns about interpretability and transparency. This places a central paradox to the domain: the pursuit of top predictive precision against the practical need for reliable models that enable straightforward, sound explanations in high-risk financial scenarios.

4. PERFORMANCE EVALUATION AND APPLICATIONS

4.1. Common Performance Metrics

The evaluation of financial forecasting models, particularly those integrating wavelet analysis and machine learning, relies on a set of standard performance metrics. These metrics provide quantitative measures of a model's accuracy, error magnitude, and classification ability. Understanding these metrics is crucial for comparing the efficacy of different hybrid approaches.

Commonly reported metrics in the reviewed literature include:

- **Error Metrics (for regression tasks like price prediction):**
 - **Root Mean Squared Error (RMSE):** Measures the square root of the average of squared differences between predicted and actual values. It penalizes larger errors more heavily. Lower RMSE indicates better fit [2].
 - **Mean Absolute Error (MAE):** Calculates the average of the absolute differences between predicted and actual values. It gives a direct measure of the average error magnitude. Lower MAE is preferable [2]. The error rate calculation $e = (\sum_{i=1}^n |r_i - p_i|) \div n$ used in the TRNN study is equivalent to MAE.
 - **Mean Absolute Percentage Error (MAPE):** Expresses the average absolute error as a percentage of the actual values. It helps compare forecast accuracy across time series with different scales. Lower MAPE indicates higher accuracy [44].

- **Accuracy Metrics (for classification tasks like predicting price direction - up/down):**
 - **Accuracy:** The proportion of correct predictions (both true positives and true negatives) among the total number of cases. Higher accuracy is better [55].
 - **F1-Score:** The harmonic mean of precision and recall. It is a valuable measure when dealing with imbalanced classes. A higher F1-Score indicates better classification performance [55].
 - **Area Under the ROC Curve (AUC):** The AUC represents the model's ability to distinguish between positive and negative classes. An AUC of 1 indicates a perfect classifier, while 0.5 suggests a random classifier. Higher AUC is better [55].
- **Goodness-of-Fit Metrics:**
 - **R-squared (R2):** Represents the proportion of the variance in the dependent variable that is predictable from the independent variable(s). A higher R2 (closer to 1) indicates a better fit of the model to the data [55].
 - **Directional Accuracy / Hit Ratio:** Specifically measures the percentage of times the model correctly predicts the direction of price movement (*e.g.*, up or down), which is often more critical for trading decisions than the exact price forecast [69].

4.2. Benchmarking and Comparative Analysis

A central theme emerging from the reviewed literature is the enhanced efficacy of hybrid wavelet-ML models compared to their standalone counterparts or traditional statistical methods Table 2.

- **Versus Standalone ML Models:** Studies consistently demonstrate that integrating wavelet analysis as a preprocessing or feature-engineering step significantly improves ML model performance. For example, [16] showed that their DWT-ELM (DELM) model achieved substantially higher accuracy and AUC values in stock trend prediction compared to a standard ELM model trained on raw data. Similarly, [44] reported that a Wavelet-LSTM model achieved over a 30% gain in accuracy (reduction in error metrics) compared to a standalone LSTM model for forecasting spice prices. The research on the WT-Att-LSTM model for the NIFTY 50 index also found it outperformed an Attention-LSTM (without wavelets) and a basic LSTM model, with ablation studies confirming the positive contribution of wavelet denoising [55, 6] reported accuracy increases ranging from 15.89% to 19.59% for various stock indices when using their DWT-CSO feature engineering approach with ML/DL models compared to models without this wavelet-based feature processing.
- **Versus Traditional Statistical Models:** Wavelet-ML hybrid models also tend to outperform traditional time-series models such as ARIMA or GARCH. For instance, [80], whose stacked deep learning model incorporated wavelet denoising, found that their approach for Bitcoin forecasting outperformed ARIMA. The TRNN model, an optimized RNN with its own advanced time-domain preprocessing, was also shown to

outperform ARIMA and GARCH models in stock price prediction [2].

The robust performance of wavelet-ML hybrid models over wavelet-less models supports the central hypothesis of this research domain, which asserts that resorting to wavelet transforms to address the problems of noise and non-stationarity in financial data is necessary for more precise forecasting. Wavelets improve signals and help construct richer, more informative features that ML models use to identify patterns and improve their generalization performance on novel datasets.

It is more than simply incorporating a better performing ML model. It is indicative of the value added from sophisticated layers of data abstraction and robust learning paradigms. The results show that the effectiveness of the used technique depends on the assumed preprocessing paradigm, thereby substantiating the notion that "the more sophisticated the data, the more sophisticated model one is required to use," which comes from the domain of learning from data.

4.3. Applications Across Diverse Financial Markets

The application of hybrid wavelet-ML models spans a wide range of financial markets and forecasting tasks, demonstrating the approach's versatility.

- **Stock Market Forecasting:**
 - **Prices and Indices:** A considerable segment remains investment in propensity prediction of stock prices and stock market indices. This is represented by the WT-Att-LSTM model developed for the NIFTY 50 [55] and by the DWT-CSO model used for NIFTY50, BSE (India), S&P500, and DJI (US) indices [6], DWT-ELM for stock market trend forecasting [16, 92, 96, 97] and MRA-RNN for some U.S. stocks [10] and SWT-OGRU model for stocks of individual companies such as Apple and Netflix [6]. Also, wavelet-transform-based is the TRNN model [2], which has focused on the Dow Jones Index.
 - **Turning Points:** Knowing when a market starts to rise and when it starts to fall is crucial for any trader. Wavelet analyses of these issues often involve decomposing the residuals of a forecasting system's internal model to extract internal cyclical components. In a line of work now referenced in contemporary research, applied wavelet MRA to the US, UK, and China markets. More research has shown that DWT-based denoising can highlight the more stable trends, thereby assisting in the identification of turning points. The TRNN model integrates DNN-based turning point detection, as described by some researchers. Wavelet analysis in the context of stock markets is one of the most efficient methods for measuring instantaneous price changes and determining, in real time, the price fluctuations that activate the market. This is achieved by enhancing the clarity of the underlying trend components, which can be obscured by short-term noise [98]. By isolating these trends, wavelets can make it easier for models, and even for experts conducting visual analysis, to detect momentum shifts that often signal impending market reversals.

Table 2. Comparative summary table.

Reviewed Method/Model	Dataset Used	Key Performance Metrics Reported (Value)	Notes on Computational Cost
Discrete Wavelet Transform [41].	Dow Jones Industrial Average (DJIA30)	Autocorrelation Function (ACF) measures the stationarity and "noisiness" of the data after the DWT is applied.	-
BSd-RNN. [42]	Monthly historical volatility (HV) from S&P 500, NASDAQ, DJIA, and NYSE.	FRMSE: 0.0022 FMAE: 0.0012 FMAPE: 0.0231	B-spline wavelets use matrices that enable linear algorithms, increasing the model's efficiency.
Wavelet Deep average model. [43]	Bitcoin (BTC), Dogecoin, Ethereum (ETH), and Bitcoin Cash (BCH)	Price prediction was an MAE of 1.19. illiquidity prediction was an MAE of 1.49.	The model was implemented using the Keras library with a TensorFlow backend. Specific network settings included a batch size of 64 and a learning rate of 0.0001.
Wavelet LSTM model. [44]	Monthly wholesale price data from various markets across India.	Root Mean Square Error (RMSE), Mean Absolute Percentage Error (MAPE), and Mean Absolute Error (MAE). Wavelet LSTM model gain in accuracy of more than 30% compared to the standard LSTM	significant limitation of wavelet-based denoising is that it can be computationally intensive.
SWIFT [45]	Traffic, Electricity, Weather, and four subsets of the ETT dataset	SWIFT achieved an MSE of 0.0129, significantly outperforming models like FITS (0.0376) and Transformer (0.0384)	The SWIFT-Linear variant has only 18.1k parameters, which is 4 times fewer than a standard single-layer linear model and roughly 15% of the parameters of another lightweight model, FITS.
This is a comparative analysis paper that uses the Haar Wavelet and the Daubechies Wavelet [40].	S&P GREEN BND SELECT INDEX - PRICE INDEX	Energy Distribution: 85.51% Entropy Coefficients: 0.6231	Haar wavelet as "a straightforward and effective wavelet" , Daubechies wavelet as "a more sophisticated wavelet with more smoothness and accuracy"
Non-Decimated Wavelet Transform (NDWT) and Non-Decimated Wavelet Packet Transform (NWPT) [51]	UK National Grid electricity supply, Hourly measurements from Heathrow, Simulated Data	Primary evaluation metric is the Symmetric Mean Absolute Percentage Error (SMAPE), NDWT features led to a 31% reduction in SMAPE for Multilayer Perceptron (MLP) models and an 11% reduction for XGBoost models	Approximately 140 hours to run on a computer with an Intel i9-9920X CPU and an NVIDIA GeForce RTX 3080 Ti GPU.
Hybrid ARIMA-wavelet [52]	USA monthly electricity demand data	RMSE decreased by 24.6%. MAE decreased by 23.7%. MAPE decreased by 23.5%.	Sigma XL and MATLAB software.
The study evaluates several machine learning models: Gradient Boosting Machine (GBM) with Bayesian Optimization, LSTM, and Autoencoder [55]	Historical financial and operational data from a manufacturing firm	Cost Estimation: MAPE (4.9%) Financial Forecasting: sMAPE (7.9%)	Training times for its best-performing models: 7.10 seconds for the hybrid GBM model and 5.78 seconds for the LSTM model.
Time-series Recurrent Neural Network (TRNN)dependencies [2].	Dow Jones Index	Prediction Error Rate: TRNN: 9.23% LSTM: 14.4% ARIMA: 15.54% RNN: 16.4% GARCH: 37.63%	2.8 GHz Intel Core i7-1165 CPU and 32 GB of RAM. The programs were written in C# and Python 3.7, using TensorFlow 1.13.1.

EWT-attention-LSTM [73]	<p>Case 1: Monthly industrial electricity consumption in Hubei Province, China</p> <p>Case 2: Monthly total electricity consumption of China</p> <p>Case 3: Monthly petroleum products consumption of the United States</p>	<p>MAPE values for the proposed EWT-attention-LSTM model:</p> <p>Case 1 (Hubei Electricity): 4.01%.</p> <p>Case 2 (China Electricity): 5.37%.</p> <p>Case 3 (US Petroleum): 1.60%.</p>	<p>For all experiments, the models used data from the previous three months (t-3) to forecast the target variable for the current month (t).</p>
DELM (Denoised Extreme Learning Machine) [88]	<p>Study used a dataset of 400 stocks from the Shanghai and Shenzhen stock markets in China.</p>	<p>Accuracy (Acc): 0.7013</p> <p>AUC: 0.6892</p> <p>Precision (P): 0.6681</p> <p>F1 Score: 0.6369</p> <p>Recall (R): 0.6257</p>	<p>Efficiency of the Extreme Learning Machine (ELM) component, noting its fast convergence and learning speed compared to traditional gradient-based algorithms like backpropagation.</p>
Multi-layer Perceptron (MLP), Convolutional Neural Network (CNN), and Long Short-Term Memory (LSTM) [87].	<p>10-year (2009–2019) daily adjusted stock price data for four major US companies: Coca-Cola, Cisco Systems, Nike, and Goldman Sachs.</p>	<p>Primary metric used was the Area Under ROC Curve (AUC) to account for class imbalance. LSTM model achieved an AUC of almost 0.85 on the Cisco Systems data.</p>	<p>The paper notes a trade-off between performance and efficiency's model produced superior results but is described as a "computationally expensive algorithm that requires a long time to train".</p>
WT-Att-LSTM [55].	<p>Daily data from the NIFTY 50 index</p>	<p>RMSE (Root Mean Squared Error): 0.0302</p> <p>MAE (Mean Absolute Error): 0.0234</p> <p>R² (R-squared): 0.9777</p>	<p>The paper focuses on the model's architecture and predictive accuracy. It does not provide specific details on the computational cost, training time, or overall efficiency of the WT-Att-LSTM model.</p>
Multi-modality Graph Neural Network (MAGNN) [91]	<p>All 3714 public companies in the China A-shares market</p>	<p>Weighted-F1: 0.4825</p> <p>Micro-F1: 0.4838</p> <p>Macro-F1: 0.4627</p>	<p>The MAGNN model, written in TensorFlow, takes 2 hours to train on 2 Tesla P100 GPUs.</p>
Artificial Neural Networks (ANN) and Support Vector Machines (SVM) [93]	<p>Stock indices like NASDAQ, S&P 500, KOSPI, and NIFTY</p>	<p>ANN: Reported accuracy varies significantly across models and datasets. Some studies achieved accuracies of 98% and 96.22% (R² scores). More commonly, accuracy ranges between 68% and 90%.</p> <p>SVM: Simple SVM models typically show an accuracy of about 60%–70%.</p>	<p>SVM: Is noted to "fall short when dealing with large datasets" because it can require high computational power and be time-consuming to run.</p> <p>ANN: The primary time cost is not in running the model but in finding the optimal network configuration, which is described as a "trial and error game" that can be "tedious and periodically time-consuming".</p>
Deep stacking ensemble model [80]	<p>Bitcoin (BTC) data sourced from bitinfocharts</p>	<p>Mean Absolute Percentage Error (MAPE) of 0.58%</p>	<p>Deep learning approaches tend to take longer to execute than traditional machine learning methods.</p>
The study compares the performance of a simple Recurrent Neural Network (RNN) and its two main variants: Long Short-Term Memory (LSTM) and Gated Recurrent Unit (GRU) [94].	<p>Stock market indices and currency exchange rates</p>	<p>The models were evaluated using Root Mean Squared Error (RMSE) and Mean Absolute Error (MAE). The GRU model achieved the best overall performance.</p>	<p>The paper notes that the LSTM model has many parameters, which "requires a large computational power, making the data processing slow."</p>

- **Commodity Market Forecasting:**

- The forecasting of commodity prices, including agricultural products and energy, has benefited from the integration of wavelet-ML. [44] demonstrated significant improvements in forecasting spice prices using a Wavelet-LSTM model. [56] proposed combining wavelet-based divergence measures with LSTMs to predict commodity prices under conditions of economic and financial uncertainty.

- **Cryptocurrency Market Forecasting:**

- The very volatile and noisy characteristics of cryptocurrency markets makes them a challenging but suitable environment for wavelet-ML applications. [8] applied Haar wavelet noise reduction to a stacked deep learning model (consisting of LSTMs, GRUs, and Transformers) for the prediction of Bitcoin prices and movement. [43] proposed WDA model to combine wavelet features (features selected through Random Forest) and simple averaging of the deep learning models to predict the prices and illiquidity of multiple sets of cryptocurrencies (BTC, Dogecoin, Ethereum, *etc.*). It is interesting to use wavelets in these markets, as traditional models may fail because of the extreme data properties. Wavelet denoising and advanced feature extraction are necessary to extract a discernible pattern from the highly stochastic nature of cryptocurrency price series. The findings in those papers show that wavelet-ML hybrids could be an exciting tool for navigating the maze of cryptocurrency forecasting, and, in the case of ripple, at least in stable, mature, less noisy traditional markets.

- **Volatility Forecasting:**

- Forecasting financial volatility is important for risk management and option pricing. Wavelet analysis has also been used by [71, 99, 100], employing wavelet entropy along with DL models to predict forex volatility. Other research describes a framework that integrates a Triple-Discriminator Generative Adversarial Network (GAN) with the Continuous Wavelet Transform (CWT) to decompose the volatility time series into signal-like and noise-like frequency components for independent monitoring and detection [101]. Due to wavelet decomposition of signals into various frequencies, wavelets can also directly help track and model volatility. The volatility itself is a multiscale, time-dependent phenomenon: it clusters, evolves, and behaves differently in the short-term and the long run. High-frequency detail coefficients in wavelet decomposition can equivalently refer to short-term volatility, and lower-frequency approximation constituent may indicate medium (long) term trends in volatility. As a consequence, wavelets offer a natural and practical approach to capturing the multi-scale nature of volatility and enable better modeling, potentially resulting in more accurate forecasts than models based solely on raw price returns.

5. CHALLENGES AND LIMITATIONS IN APPLYING WAVELET ANALYSIS WITH MACHINE LEARNING

Despite the promising results achieved by hybrid wavelet-ML models, their application in financial forecasting poses challenges and limitations. Addressing these is crucial for the continued advancement and practical adoption of these techniques.

5.1. Choice of Mother Wavelet

Determining the appropriate wavelet transform for financial time series analysis is a complex yet essential task in wavelet-based modeling [13]. Each of the mother wavelets, such as Haar, Daubechies, Symlets, and Coiflets, has its own symmetrical, mathematically distinctive properties of compact support and the number of vanishing moments. These traits impact the way a wavelet is able capture the features of the financial time series. Using the wrong wavelet can lead to insufficient decomposition, ineffective noise suppression, and insufficient feature extraction, which, in turn, negatively affect the subsequent machine learning model's performance.

For instance, [44] explores the use of the Daubechies and Haar wavelets in forecasting agricultural prices, while [52] cross-validated to Daubechies configurations having different degrees of vanishing moments to optimize performance. These studies illustrate the absence of a single definitive criterion for selecting mother wavelets for financial datasets. Typically, selection is conducted on an ad hoc basis based on data smoothing, gaps, and the wavelet and signal processing literature, which often fails to capture the intricacies of financial time series.

5.2. Determining Optimal Decomposition Level

Decomposition levels in a wavelet transform are as important as the selection of the corresponding mother wavelet [44]. The decomposition level determines the level of detail in the multi-resolution analysis. With too few levels, important frequency components are more likely to be combined, making it harder to distinguish patterns from noise. With too many levels, excessive complexity, and the addition of spurious components, the wavelet transforms, especially the Wavelet Packet Transform (WPT), becomes problematic due to significantly higher computational costs.

In a previous study [44], it was determined that a decomposition level of H6 yielded the best results with the Haar wavelet and LSTM model. Other model-spice combinations, however, achieved optimal performance at different levels, such as H5 or H7. The growing need for parameter tuning and model validation is underscored by the need to adapt to the variety of datasets.

5.3. Selection of Thresholding Rules and Values for Denoising

The success of hybrid modeling depends on the efficiency of done in the wavelet transform denoising process. Which depends on two rules. One is the thresholding rules (hard, soft, Garrote), and the other is the method for computing the threshold (universal methods like VisuShrink and adaptive methods like SUREshrink) [55]. Failure of thresholding results in dire consequences. An extremely conservative threshold keeps the data too dirty, forcing the machine learning model to work on it. An aggressive threshold, on the other hand, leads to aggressive signal information extraction, resulting in the complete loss of vital financial features due to excessive overshooting.

A straightforward example is [16]. While many works used fixed threshold parameters, others claimed that, for the DWT-ELM model, such parameters do not perform well under varying data conditions [102].

5.4. Risk of Overfitting

This multitude of parameters, formed by selecting a wavelet's mother, its decomposition levels, and its subsequent thresholding, along with training an ML model on the altered dataset, is sure to provide a wide range of options for constructing the model. This ease of construction, however, comes at a cost: an increased risk of overfitting. This, along with her concern about the wavelet-ML model in conjunction with machine learning, might make the model overly tailored to the training dataset. In the case above, the model might learn underlying trends and remove a portion of the overlying noise, hence the name "residual noise". Thus, in the case where the model performs exceedingly well on in sampling and specific tests, the model is just trying to derive relationships between seen objects and fails in the case of the real world, a revelation that is unheard of in financial forecasting, is a testament to the level of over-fitting that has been done.

To combat this, steps such as rigorous cross-validation and overfitting-preventing mechanisms are key. This has been highlighted in the case of wavelets' overfitting about the optimal number of wavelets selected via cross-validation [51]. In the end, the goal is to determine whether the noise and inherited characteristics of the chosen sample skew the model's performance assessment in a way that does not reflect the actual complexities of the market and its underlying behavioral mechanisms [98].

5.5. Computational Cost and Practical Implementation

While implementing wavelet-based models, it is important to strike the right balance between model performance and computational cost. Various components contribute to the overall computational demand, including the chosen mother wavelet, the number of decomposition levels, and the size of the set under analysis. Generally, increasing the decomposition level provides a more granular analysis but also increases computation time and memory requirements. There are several accessible software libraries for implementing these methods. In Python, the PyWavelets library is the standard for wavelet transforms, offering a wide range of wavelet families and functions for decomposition and denoising. For MATLAB users, the Wavelet Toolbox™ provides a comprehensive graphical and command-line environment for analyzing, synthesizing, and processing signals.

CONCLUSION

Financial forecasting is an age-old problem and one of the most challenging for quantitative analysis, primarily because financial time series data are complex, with pervasive noise, non-stationarity, and non-linearity. In many situations, these complex patterns cannot be fully accounted for by classical statistical models. This paper collates an extensive body of peer-reviewed literature to show that the maturation of wavelet transforms with machine learning is indeed an important and inevitable paradigm shift across the field.

The primary conclusion is that the wavelet is not simply an addition to other analysis techniques; it is an independent, robust, and constructive approach to analysis that enriches the quality of financial data, particularly in effective feature denoising and multi-scale extraction. The application of the wavelet transform enables a sophisticated machine learning model, such as an LSTM or a Transformer, to work with a dataset that has been significantly

structured, denoised, and information-rich [66, 67]. This is the rationale for the outperformance of such hybrid models relative to their individual components, and the superior predictive performance has been attributed to the enhanced data representation. This thesis demonstrates the versatility and effectiveness of this model across markets ranging from simple stocks to chaotic cryptocurrencies.

Despite the positive outcomes of hybrid models, their actual use is still hampered by problems. Selecting suitable parameters, such as the mother wavelet, decomposition level, and thresholding rules, remains very important and sometimes tedious, but crucial within the context of wavelet analysis. It is still dependent on the daily activity data, and forecasting becomes tedious within the other boundaries of wavelet analysis. Additionally, the complex nature of such systems is prone to overfitting, as with other deep learning models, which act as major hindrances to interpretability and confidence within institutions. Thus, the following steps should provide more transparent wavelet methods, along with other hybrids. This collection of papers is built on cornerstones that provide a controlled wavelet transform for predictive analysis. Deep learning systems, which provide a paradigm shift from traditional systems, are set as the powerful frontier.

The WT's ability to decompose signals into different time-frequency scales at its heart provides a specific solution to the problematic aspects of financial time series, notably non-stationarity, ubiquitous noise, and volatility clustering [79, 89, 90]. The multiresolution analysis property of this can help develop two key application techniques essential to financial forecasting: efficient denoising of financial time series allows separation of the underlying model from random noise, and feature selection at multiple scales is obtained from wavelet coefficients.

The superior predictive performance of hybrid models which combine wavelet features with different machine learning and deep learning techniques has been consistently corroborated in the literature. This is not a trivial increase in performance. It also underscores the importance of the quality and representativeness of the input data. Noise reduction and structural clarification of data with wavelets enable machine learning models to work with less chaotic, more organized information. Consequently, these models are better at uncovering the actual patterns and intricacies of the data. This has been proven in several domains, including the denser domain of financial markets such as traditional stocks and cryptocurrencies where wavelet denoising makes pattern recognition more accessible, which would otherwise be difficult.

Although positive, such models have significant drawbacks. Parameter tuning of wavelet-based systems is not trivial. The numerous adjustable parameters in both the wavelet and the machine learning components present overfitting risks. Further, the already problematic interpretability of these models, due to the "black box" nature of complex systems, leads to distrust and non-adoption, especially in institutions. These challenges highlight the advanced but delicate position the field is in. There is an extreme need to fine-tune and expand the technical approaches to realize the next set of gains.

Future research, however, has already begun to branch into these more innovative, still untapped directions. We expect the next wave of breakthroughs to emerge from real-time adaptive wavelet

techniques that select optimal parameters autonomously, as well as from the development of more understandable and robust hybrid models. Such achievements would both enhance the accuracy of these models and the confidence needed to deploy them in the intricate financial markets.

The literature highlights several possible ways to address the current shortcomings. One technique is the development of adaptive wavelet methods, in which the components of the financial time series, such as the mother wavelet, decomposition level, and thresholding hyperparameters, can change over time. This may improve adaptability, robustness, and the overall simplicity of the methods by eliminating the need for manual tuning. At the same time, other researchers are developing more complex hybrid models that incorporate new wavelet types and deeper architectures, such as Transformers and Graph Neural Networks. These works have to be complemented with new developments of interpretability, for instance by redesigning attention mechanisms to facilitate model explainability. This range of activities exemplifies a broader trend in AI, driven by the XAI and AutoML movements, to create models that are not only powerful but also reliable and explainable.

LIST OF ABBREVIATIONS

ANNs	=	Artificial Neural Networks
ARIMA	=	Autoregressive Integrated Moving Average
DL	=	Deep Learning
EMH	=	Efficient Market Hypothesis
GARCH	=	Generalized Autoregressive Conditional Heteroskedasticity
LSTM	=	Long Short-Term Memory
ML	=	Machine Learning
MRA	=	Multi-Resolution Analysis
RNNs	=	Recurrent Neural Networks
SVMs	=	Support Vector Machines
TFR	=	Time-Frequency Representation
WT	=	Wavelet Transforms
WDA	=	Wavelet Deep Average

AUTHORS' CONTRIBUTIONS

K.K.L. and R.A. has contributed to conceptualization, idea generation, problem statement, methodology, results analysis, results interpretation.

CONSENT FOR PUBLICATION

Not applicable.

AVAILABILITY OF DATA AND MATERIALS

The data will be made available on reasonable request by contacting the corresponding author [K.K.L].

FUNDING

None.

CONFLICT OF INTEREST

The authors declare that there is no conflict of interest regarding the publication of this article.

ACKNOWLEDGEMENTS

Declared none.

DECLARATION OF AI

During the preparation of this work the authors used ChatGPT for editing purposes. After using this tool, the authors reviewed and edited the content as needed and take full responsibility for the content of the published article.

DISCLOSURE

The authors declare that portions of this article (text, data, or figures) are adapted from their previously published work titled "Integration of Time-series Recurrent Neural Network Model (TRNN) with Wavelet Transform to Improve Stock Price Prediction", published in Student Paper Repository, Universiti Putra Malaysia (UPM) in 2025. The reused material has been appropriately cited, and the present manuscript includes substantial new analysis, interpretation, and findings beyond the original publication.

REFERENCES

- [1] Wang J, Hong S, Dong Y, Li Z, Hu J. Predicting stock market trends using LSTM networks: overcoming RNN limitations for improved financial forecasting. *J Comput Sci Softw Appl.* 2024; 4(3): 1-7. <http://doi.org/10.5281/zenodo.12200708>
- [2] Lu M, Xu X. TRNN: an efficient time-series recurrent neural network for stock price prediction. *Inf Sci.* 2024; 657: 119951. <http://doi.org/10.1016/j.ins.2023.119951>
- [3] Tanaka Y, Hashimoto R, Takayanagi T, Piao Z, Murayama Y, Izumi K. CoFinDiff: controllable financial diffusion model for time series generation. *arXiv.* 2025; 2503.04164. <http://doi.org/10.24963/ijcai.2025/1040>
- [4] Herskovic B, Kelly B, Lustig H, Van Nieuwerburgh S. The common factor in idiosyncratic volatility: quantitative asset pricing implications. *J Financ Econ.* 2016; 119(2): 249-283. <http://doi.org/10.1016/j.jfineco.2015.09.010>
- [5] Timmermann A. Forecasting methods in finance. *Annu Rev Financ Econ.* 2018; 10(1): 449-479. <http://doi.org/10.1146/annurev-financial-110217-022713>
- [6] Mamba LS, Ngunyi A, Nderu L. Predicting wavelet-transformed stock prices using a vanishing gradient resilient optimized gated recurrent unit with a time lag. *J Data Anal Inf Process.* 2023; 11(1): 49-68. <http://doi.org/10.4236/jdaip.2023.111004>

- [7] Olubusola O, Mhlongo NZ, Daraojimba DO, Ajayi-Nifise AO, Falaiye T. Machine learning in financial forecasting: a US review: exploring the advancements, challenges, and implications of AI-driven predictions in financial markets. *World J Adv Res Rev.* 2024; 21(2): 1969-1984. <http://doi.org/10.30574/wjarr.2024.21.2.0444>
- [8] Karaev AK, Gorlova OS, Ponkratov VV, Sedova ML, Shmigol NS, Vasyunina ML. A comparative analysis of the choice of mother wavelet functions affecting the accuracy of forecasts of daily balances in the treasury single account. *Economies.* 2022; 10(9): 213. <http://doi.org/10.3390/economies10090213>
- [9] Olamijuwon NJ, Zouo NSJC. Machine learning in budget forecasting for corporate finance: a conceptual model for improving financial planning. *Open Access Res J Multidiscip Stud.* 2024; 8(2): 32-40. <http://doi.org/10.53022/oarjms.2024.8.2.0061>
- [10] Peng L, Chen K, Li N. Predicting stock movements: using multiresolution wavelet reconstruction and deep learning in neural networks. *Information.* 2021; 12(10): 388. <http://doi.org/10.3390/info12100388>
- [11] Turhan-Sayan G, Sayan S. Use of time-frequency representations in the analysis of stock market data. In: *Computational Methods in Decision-Making, Economics and Finance.* Boston (MA): Springer; 2002. p. 429-453. http://doi.org/10.1007/978-1-4757-3613-7_22
- [12] Althelaya KA, Mohammed SA, El-Alfy ES. Combining deep learning and multiresolution analysis for stock market forecasting. *IEEE Access.* 2021; 9: 13099-13111. <http://doi.org/10.1109/ACCESS.2021.3051872>
- [13] Rabbouch H, Rabbouch B, Saâdaoui F. Multiresolution data analytics for financial time series using MATLAB. In: *Data Analytics for Management, Banking and Finance: Theories and Application.* Cham: Springer Nature Switzerland; 2023. p. 113-134. http://doi.org/10.1007/978-3-031-36570-6_5
- [14] Tang Y, Song Z, Zhu Y, Yuan H, Hou M, Ji J, et al. A survey on machine learning models for financial time series forecasting. *Neurocomputing.* 2022; 512: 363-380. <http://doi.org/10.1016/j.neucom.2022.09.003>
- [15] Struzik ZR. Wavelet methods in (financial) time-series processing. *Physica A.* 2001; 296(1-2): 307-319. [http://doi.org/10.1016/S0378-4371\(01\)00101-7](http://doi.org/10.1016/S0378-4371(01)00101-7)
- [16] Wu D, Wang X, Wu S. A hybrid method based on extreme learning machine and wavelet transform denoising for stock prediction. *Entropy.* 2021; 23(4): 440. <http://doi.org/10.3390/e23040440>
- [17] Vogl M, Rötzel PG, Homes S. Forecasting performance of wavelet neural networks and other neural network topologies: a comparative study based on financial market data sets. *Mach Learn Appl.* 2022; 8: 100302. <http://doi.org/10.1016/j.mlwa.2022.100302>
- [18] Sonkavde G, Dharrao DS, Bongale AM, Deokate ST, Doreswamy D, Bhat SK. Forecasting stock market prices using machine learning and deep learning models: a systematic review, performance analysis and discussion of implications. *Int J Financ Stud.* 2023; 11(3): 94. <http://doi.org/10.3390/ijfs11030094>
- [19] Zheng H, Wu J, Song R, Guo L, Xu Z. Predicting financial enterprise stocks and economic data trends using machine learning time series analysis. *Appl Comput Eng.* 2024; 87(1): 26-32. <http://doi.org/10.54254/2755-2721/87/20241562>
- [20] Budu K. Comparison of wavelet-based ANN and regression models for reservoir inflow forecasting. *J Hydrol Eng.* 2014; 19(7): 1385-1400. [http://doi.org/10.1061/\(ASCE\)HE.1943-5584.0000892](http://doi.org/10.1061/(ASCE)HE.1943-5584.0000892)
- [21] Zhang BL, Coggins R, Jabri MA, Dersch D, Flower B. Multiresolution forecasting for futures trading using wavelet decompositions. *IEEE Trans Neural Netw.* 2001; 12(4): 765-775. <http://doi.org/10.1109/72.935090>
- [22] Shoushtari F, Najafi Zadeh MS, Ghafourian H, Karim Zadeh E. Applications of machine learning in financial accounting for industrial engineering: a case study on cost estimation and forecasting. *SSRN.* 2024. <http://doi.org/10.2139/ssrn.4991489>
- [23] Shah FA, Debnath L. Wavelet neural network model for yield spread forecasting. *Mathematics.* 2017; 5(4): 72. <http://doi.org/10.3390/math5040072>
- [24] Pont O, Turiel A, Perez-Vicente CJ. Description, modelling and forecasting of data with optimal wavelets. *J Econ Interact Coord.* 2009; 4(1): 39-54. <http://doi.org/10.1007/s11403-009-0046-x>
- [25] Tang Q, Shi R, Fan T, Ma Y, Huang J. Prediction of financial time series based on LSTM using wavelet transform and singular spectrum analysis. *Math Probl Eng.* 2021; 2021: 9942410. <http://doi.org/10.1155/2021/9942410>
- [26] Kim JM, Kim DH, Jung H. Applications of machine learning for corporate bond yield spread forecasting. *N Am J Econ Finance.* 2021; 58: 101540. <http://doi.org/10.1016/j.najef.2021.101540>
- [27] Ababneh F, Al Wadi S, Ismail MT. Haar and Daubechies wavelet methods in modeling banking sector. *Int Math Forum.* 2013; 8(12): 551-566. <http://doi.org/10.12988/imf.2013.13056>
- [28] Ozun A, Cifter A. Modeling long-term memory effect in stock prices: a comparative analysis with GPH test and Daubechies wavelets. *Stud Econ Finance.* 2008; 25(1): 38-48. <http://doi.org/10.1108/10867370810857559>
- [29] Zhang Z, Guo D, Zhou S, Zhang J, Lin Y. Flight trajectory prediction enabled by time-frequency wavelet transform. *Nat Commun.* 2023; 14(1): 5258. <http://doi.org/10.1038/s41467-023-40903-9>
- [30] Grobelaar M, Phadikar S, Ghaderpour E, Struck AF, Sinha N, Ghosh R, et al. A survey on denoising techniques of electroencephalogram signals using wavelet transform. *Signals.* 2022; 3(3): 577-586. <http://doi.org/10.3390/signals3030035>
- [31] Kikuchi T. Wavelet analysis of cryptocurrencies: nonlinear dynamics in high frequency domains. *arXiv.* 2024; 2411.14058. <http://doi.org/10.2139/ssrn.5029223>
- [32] Li Z, Tam V. Combining the real-time wavelet denoising and long short-term memory neural network for predicting stock indexes. In: *2017 IEEE Symposium Series on Computational Intelligence (SSCI);* 2017. p. 1-8. <http://doi.org/10.1109/SSCI.2017.8280883>

- [33] Xie Y, Yu J, Ranney B. Forecasting using locally stationary wavelet processes. *J Stat Comput Simul.* 2009; 79(9): 1067-1082. <http://doi.org/10.1080/00949650802087003>
- [34] Akinkunmi WB, Phillips SA, Omotola AA, Nuga KA. Comparative analysis of Haar and Daubechies statistical wavelets for financial time series analysis. In: Royal Statistical Society Nigeria Local Group Annual Conference Proceedings; 2025. p. 1-9. Available from: <https://publications.funaab.edu.ng/index.php/RSS/article/view/1920/1596>
- [35] Dghais AA, Ismail MT. A study of stationarity in time series by using wavelet transform. In: AIP Conf Proc. 2014; 1605(1): 798-804. <http://doi.org/10.1063/1.4887692>
- [36] Hajiabotorabi Z, Kazemi A, Samavati FF, Ghaini FM. Improving DWT-RNN model via B-spline wavelet multiresolution to forecast a high-frequency time series. *Expert Syst Appl.* 2019; 138: 112842. <http://doi.org/10.1016/j.eswa.2019.112842>
- [37] Alireza N, Ali A, Mohammad N, Ramin N, Sasan N. Wavelet transform and deep weight averaging model for price and illiquidity prediction of cryptocurrencies using high-dimensional features. *Res Square.* 2025. <http://doi.org/10.21203/rs.3.rs-6324973/v1>
- [38] AlSharabi K, Salamah YB, Abdurraqueeb AM, Aljalal M, Alturki FA. EEG signal processing for Alzheimer's disorders using discrete wavelet transform and machine learning approaches. *IEEE Access.* 2022; 10: 89781-89797. <http://doi.org/10.1109/ACCESS.2022.3198988>
- [39] Tuñón EA. Servicios bancarios: estudiantes de Lic. Finanzas y Banca. Centro Regional Universitario de Coclé. Año 2023. *Rev Cient Salud Desarro Hum.* 2025; 6(1): 1990-2008. <http://doi.org/10.61368/r.s.d.h.v6i1.579>
- [40] Gu Q, Chang Y, Xiong N, Chen L. Forecasting nickel futures price based on the empirical wavelet transform and gradient boosting decision trees. *Appl Soft Comput.* 2021; 109: 107472. <http://doi.org/10.1016/j.asoc.2021.107472>
- [41] Elias II, Ali TH. Optimal level and order of the Coiflets wavelet in the VAR time series denoise analysis. *Front Appl Math Stat.* 2025; 11: 1526540. <http://doi.org/10.3389/fams.2025.1526540>
- [42] Gosala B, Kapgate PD, Jain P, Chaurasia RN, Gupta M. Wavelet transforms for feature engineering in EEG data processing: an application on schizophrenia. *Biomed Signal Process Control.* 2023; 85: 104811. <http://doi.org/10.1016/j.bspc.2023.104811>
- [43] Tamilselvi C, Yeasin M, Paul RK, Paul AK. Can denoising enhance prediction accuracy of learning models? A case of wavelet decomposition approach. *Forecasting.* 2024; 6(1):81-99. <http://doi.org/10.3390/forecast6010005>
- [44] Xie W, Cao F. SWIFT: mapping sub-series with wavelet decomposition improves time series forecasting. *arXiv.* 2025; 2501.16178. <http://doi.org/10.48550/arXiv.2501.16178>
- [45] Sun EW, Meinel T. A new wavelet-based denoising algorithm for high-frequency financial data mining. *Eur J Oper Res.* 2012; 217(3): 589-599. <http://doi.org/10.1016/j.ejor.2011.09.049>
- [46] Masdemont JJ, Ortiz-Gracia L. Haar wavelets-based approach for quantifying credit portfolio losses. *Quant Finance.* 2014; 14(9): 1587-1595. <http://doi.org/10.1080/14697688.2011.595731>
- [47] Nobre J, Neves RF. Combining principal component analysis, discrete wavelet transforms and XGBoost to trade in the financial markets. *Expert Syst Appl.* 2019; 125: 181-194. <http://doi.org/10.1016/j.eswa.2019.01.083>
- [48] Lu Z. Cointegration analysis of stock market returns impact based on wavelet analysis. *Am J Ind Bus Manag.* 2023; 13(10): 1069-1078. <http://doi.org/10.4236/ajibm.2023.1310059>
- [49] Dajcman S, Festic M, Kavkler A. European stock market comovement dynamics during some major financial market turmoils in the period 1997 to 2010: a comparative DCC-GARCH and wavelet correlation analysis. *Appl Econ Lett.* 2012; 19(13): 1249-1256. <http://doi.org/10.1080/13504851.2011.619481>
- [50] Zhou Z, Hu J, Wen Q, Kwok JT, Liang Y. Multi-order wavelet derivative transform for deep time series forecasting. *arXiv.* 2025; 2505.11781. <http://doi.org/10.48550/arXiv.2505.11781>
- [51] Karim SA, Karim BA, Andersson FN, Hasan MK, Sulaiman J, Razali R. Predicting Malaysia business cycle using wavelet analysis. In: 2011 IEEE Symposium on Business, Engineering and Industrial Applications (ISBEIA); 2011. p. 379-383. <http://doi.org/10.1109/ISBEIA.2011.6088841>
- [52] Nason GP, Wei JL. Leveraging non-decimated wavelet packet features and transformer models for time series forecasting. *arXiv.* 2024; 2403.08630. <http://doi.org/10.48550/arXiv.2403.08630>
- [53] Kumar M, Kumar J. Impact of Coiflet wavelet decomposition on forecasting accuracy: shifts in ARIMA and exponential smoothing performance. *Metall Mater Eng.* 2025; 31(1): 177-192. <http://doi.org/10.63278/1234>
- [54] Jaber JJ, Ismail N, Ramli S, Al Wadi S, Boughaci D. Assessment of credit losses based on ARIMA-wavelet method. *J Theor Appl Inf Technol.* 2020; 98(9): 1379-1392. Available from: <https://www.jatit.org/volumes/Vol98No9/5Vol98No9.pdf>
- [55] Schürer J. High frequency time series analysis using wavelets. POSTER 2015. Masaryk Institute of Advanced Studies; 2015. Available from: https://poster.fel.cvut.cz/poster2015/proceedings/Section_NS/M_088_Schurrer.pdf
- [56] Singh P, Jha M. Elevating stock market predictions: an attention-infused LSTM model with wavelet denoising. In: 2024 IEEE 11th Uttar Pradesh Section International Conference on Electrical, Electronics and Computer Engineering (UPCON); 2024. p. 1-5. <http://doi.org/10.1109/UPCON62832.2024.10983446>

- [57] Tsui FC, Sun M, Li CC, Sciabassi RJ. Recurrent neural networks and discrete wavelet transform for time series modeling and prediction. In: Proceedings of the IEEE International Conference on Acoustics, Speech, and Signal Processing (ICASSP); 1995. Vol. 5. p. 3359-3362. <http://doi.org/10.1109/ICASSP.1995.479705>
- [58] Doroshenko L, Mastroeni L, Mazzoccoli A. Wavelet and deep learning framework for predicting commodity prices under economic and financial uncertainty. *Mathematics*. 2025; 13(8): 1346. <http://doi.org/10.3390/math13081346>
- [59] Ferrer R, Bolós VJ, Benítez R. Interest rate changes and stock returns: a European multi-country study with wavelets. *Int Rev Econ Finance*. 2016; 44: 1-12. <http://doi.org/10.1016/j.iref.2016.03.001>
- [60] Bolman R, Boucher T. Data mining using Morlet wavelets for financial time series. In: Proceedings of the International Conference on Data Science, Technology and Applications (DATA); 2019. p. 74-83. <http://doi.org/10.5220/0007922200740083>
- [61] Saiti B, Bacha OI, Masih M. Testing the conventional and Islamic financial market contagion: evidence from wavelet analysis. *Emerg Mark Finance Trade*. 2016; 52(8):1832-1849. <http://doi.org/10.1080/1540496X.2015.1087784>
- [62] Safa K, Belatreche A, Ouadfel S, Jiang R. WALDATA: wavelet transform based adversarial learning for the detection of anomalous trading activities. *Expert Syst Appl*. 2024; 255: 124729. <http://doi.org/10.1016/j.eswa.2024.124729>
- [63] Al Wadia MT, Ismail MT. Selecting wavelet transforms model in forecasting financial time series data based on ARIMA model. *Appl Math Sci*. 2011; 5(7): 315-326. Available from: <https://www.m-hikari.com/ams/ams-2011/ams-5-8-2011/alwadiAMS5-8-2011.pdf>
- [64] Kodogiannis V, Lolis A. Forecasting financial time series using neural network and fuzzy system-based techniques. *Neural Comput Appl*. 2002; 11(2): 90-102. <http://doi.org/10.1007/s005210200021>
- [65] Islam MR, Rashed-Al-Mahfuz M, Ahmad S, Molla MK. Multiband prediction model for financial time series with multivariate empirical mode decomposition. *Discrete Dyn Nat Soc*. 2012; 2012: 593018. <http://doi.org/10.1155/2012/593018>
- [66] Huang C, Huang L, Zhong W. Chaotic time series forecasting based on CDF9/7 biorthogonal wavelet kernel support vector machine. In: Seventh International Conference on Natural Computation; 2011. Vol. 1. p. 348-352. <http://doi.org/10.1109/ICNC.2011.6022096>
- [67] Han TT, Zhao QC. Financial crisis predictions based on biorthogonal wavelet hybrid kernel support vector machine. In: 2015 11th International Conference on Natural Computation (ICNC); 2015. p. 719-724. <http://doi.org/10.1109/ICNC.2015.7378079>
- [68] Huang C, Huang LL, Han TT. Financial time series forecasting based on wavelet kernel support vector machine. In: 2012 Eighth International Conference on Natural Computation; 2012. p. 79-83. <http://doi.org/10.1109/ICNC.2012.6234569>
- [69] Kabir MR, Bhadra D, Ridoy M, Milanova M. LSTM-transformer-based robust hybrid deep learning model for financial time series forecasting. *Sci*. 2025; 7(1): 7. <http://doi.org/10.3390/sci7010007>
- [70] Ryll L, Seidens S. Evaluating the performance of machine learning algorithms in financial market forecasting: a comprehensive survey. *arXiv*. 2019; 1906.07786. <http://doi.org/10.48550/arXiv.1906.07786>
- [71] Verma S, Sahu SP, Sahu TP. Discrete wavelet transform-based feature engineering for stock market prediction. *Int J Inf Technol*. 2023; 15(2): 1179-88. <https://doi.org/10.1007/s41870-023-01157-2>
- [72] Zitis PI, Potirakis SM, Alexandridis A. Forecasting forex market volatility using deep learning models and complexity measures. *J Risk Financ Manag*. 2024; 17(12): 557. <https://doi.org/10.3390/jrfm17120557>
- [73] Cao J, Wang J. Stock price forecasting model based on modified convolution neural network and financial time series analysis. *Int J Commun Syst*. 2019; 32(12): e3987. <https://doi.org/10.1002/dac.3987>
- [74] Peng L, Wang L, Xia D, Gao Q. Effective energy consumption forecasting using empirical wavelet transform and long short-term memory. *Energy*. 2022; 238: 121756. <https://doi.org/10.1016/j.energy.2021.121756>
- [75] Chen AS, Leung MT, Daouk H. Application of neural networks to an emerging financial market: forecasting and trading the Taiwan Stock Index. *Comput Oper Res*. 2003; 30(6): 901-23. [https://doi.org/10.1016/S0305-0548\(02\)00037-0](https://doi.org/10.1016/S0305-0548(02)00037-0)
- [76] Pradeepkumar D, Ravi V. Forecasting financial time series volatility using particle swarm optimization trained quantile regression neural network. *Appl Soft Comput*. 2017; 58: 35-52. <https://doi.org/10.1016/j.asoc.2017.04.014>
- [77] Hsieh TJ, Hsiao HF, Yeh WC. Forecasting stock markets using wavelet transforms and recurrent neural networks: an integrated system based on artificial bee colony algorithm. *Appl Soft Comput*. 2011; 11(2): 2510-25. <https://doi.org/10.1016/j.asoc.2010.09.007>
- [78] Gomes GS, Ludermitr TB, Lima LM. Comparison of new activation functions in neural network for forecasting financial time series. *Neural Comput Appl*. 2011; 20(3): 417-39. <https://doi.org/10.1007/s00521-010-0407-3>
- [79] Liu K, Cheng J, Yi J. Copper price forecasted by hybrid neural network with Bayesian optimization and wavelet transform. *Resour Policy*. 2022; 75: 102520. <https://doi.org/10.1016/j.resourpol.2021.102520>
- [80] Zeng Y, Chen J, Jin N, Jin X, Du Y. Air quality forecasting with hybrid LSTM and extended stationary wavelet transform. *Build Environ*. 2022; 213: 108822. <https://doi.org/10.1016/j.buildenv.2022.108822>
- [81] Ivanyuk V, Soloviev V. Efficiency of neural networks in forecasting problems. In: 2019 Twelfth International Conference on Management of Large-Scale System Development (MLSD); 2019. p.1-4. <https://doi.org/10.1109/MLSD.2019.8911046>
- [82] Adhikari R, Agrawal RK. A combination of artificial neural network and random walk models for financial time series forecasting. *Neural Comput Appl*. 2014; 24(6): 1441-9. <https://doi.org/10.1007/s00521-013-1386-y>

- [83] Zhang Z, Pham TD, A Y, Doan NP, Alsharari M, Tran VH, et al. WaveletMixer: a multi-resolution wavelet based MLP-mixer for multivariate long-term time series forecasting. In: Proc AAAI Conf Artif Intell. 2025; 39(21): 22741-49. <https://doi.org/10.1609/aaai.v39i21.34434>
- [84] Monfared SA, Enke D. Volatility forecasting using a hybrid GJR-GARCH neural network model. *Procedia Comput Sci.* 2014; 36: 246-53. <https://doi.org/10.1016/j.procs.2014.09.087>
- [85] Al-Hashedi KG, Magalingam P. Financial fraud detection applying data mining techniques: a comprehensive review from 2009 to 2019. *Comput Sci Rev.* 2021; 40: 100402. <https://doi.org/10.1016/j.cosrev.2021.100402>
- [86] Mousa R, Afrookhteh M, Khaloo H, Bengari AA, Heidary G. Forecasting of Bitcoin prices using hashrate features: wavelet and deep stacking approach. *arXiv [Preprint].* 2025. <https://doi.org/10.48550/arXiv.2501.13136>
- [87] Li K, Li L, Tang J, Dick G, Wickert J, Yu H, et al. Research on the PWV prediction model based on the ERA5-PWV calibration and WOA-RNN-BiLSTM-multihead-attention fusion algorithms. *Atmos Res.* 2025; 108238. <https://doi.org/10.1016/j.atmosres.2025.108238>
- [88] Kamalov F. Forecasting significant stock price changes using neural networks. *Neural Comput Appl.* 2020; 32(23): 17655-67. <https://doi.org/10.1007/s00521-020-04942-3>
- [89] Ozupek O, Yilmaz R, Ghasemkhani B, Birant D, Kut RA. A novel hybrid model (EMD-TI-LSTM) for enhanced financial forecasting with machine learning. *Mathematics.* 2024; 12(17): 2794. <https://doi.org/10.3390/math12172794>
- [90] Du B, Zhou Q, Guo J, Guo S, Wang L. Deep learning with long short-term memory neural networks combining wavelet transform and principal component analysis for daily urban water demand forecasting. *Expert Syst Appl.* 2021; 171: 114571. <https://doi.org/10.1016/j.eswa.2021.114571>
- [91] Cheng D, Yang F, Xiang S, Liu J. Financial time series forecasting with multi-modality graph neural network. *Pattern Recognit.* 2022; 121: 108218. <https://doi.org/10.1016/j.patcog.2021.108218>
- [92] Kurani A, Doshi P, Vakharia A, Shah M. A comprehensive comparative study of artificial neural network (ANN) and support vector machines (SVM) on stock forecasting. *Ann Data Sci.* 2023; 10(1): 183-208. <https://doi.org/10.1007/s40745-021-00344-x>
- [93] Du W, Ge J, Sun S. Economic forecast of Southern China on BP neural network: taking Chongqing as an example. In: Proc 6th Int Conf Financial Innovation and Economic Development (ICFIED 2021); 2021. p.614-18. <https://doi.org/10.2991/aebmr.k.210319.114>
- [94] Sako K, Mpinda BN, Rodrigues PC. Neural networks for financial time series forecasting. *Entropy.* 2022; 24(5): 657. <https://doi.org/10.3390/e24050657>
- [95] Tsantekidis A, Passalis N, Tefas A, Kannianen J, Gabbouj M, Iosifidis A. Forecasting stock prices from the limit order book using convolutional neural networks. In: 2017 IEEE 19th Conf Business Informatics (CBI); 2017. Vol. 1. p.7-12. <https://doi.org/10.1109/CBI.2017.23>
- [96] Kumbure MM, Lohrmann C, Luukka P, Porras J. Machine learning techniques and data for stock market forecasting: a literature review. *Expert Syst Appl.* 2022; 197: 116659. <https://doi.org/10.1016/j.eswa.2022.116659>
- [97] Palizdar S. Short time price forecasting for electricity market based on hybrid fuzzy wavelet transform and bacteria foraging algorithm. *J Inf Syst Telecommun.* 2016; 4(16): 1. <https://doi.org/10.7508/jist.2016.04.001>
- [98] Kamalov F, Gurrib I, Rajab K. Financial forecasting with machine learning: price vs return. *J Comput Sci.* 2021; 17(3): 251-64. <https://doi.org/10.3844/jcssp.2021.251.264>
- [99] Ge W, Lalbakhsh P, Isai L, Lenskiy A, Suominen H. Neural network-based financial volatility forecasting: a systematic review. *ACM Comput Surv.* 2022; 55(1): 1-30. <https://doi.org/10.1145/3483596>
- [100] Mostafa F, Dillon T, Chang E. Computational intelligence applications to option pricing, volatility forecasting and value at risk. Cham: Springer International Publishing; 2017. <https://doi.org/10.1007/978-3-319-51668-4>
- [101] Mintarya LN, Halim JN, Angie C, Achmad S, Kurniawan A. Machine learning approaches in stock market prediction: a systematic literature review. *Procedia Comput Sci.* 2023; 216: 96-102. <https://doi.org/10.1016/j.procs.2022.12.115>
- [102] Mahase E. Global cost of overweight and obesity will hit \$4.32 tn a year by 2035, report warns. *BMJ.* 2023; 380: 523. <https://doi.org/10.1136/bmj.p523>